

Intrinsically Safe Explosion Proof Barriers

Intrinsically Safe Explosion-Proof: EB3C Relay Barriers..... 422
 Specifications..... 423
 Dimensions (mm) 425



For more information on this product family, visit our website.
 Additional resources include:

- New and updated product information
- Downloadable software demos & upgrades
- Part configuration tool & cross reference
- Online stock check & ordering
- IDEC field sales & distributor search
- Online literature request
- Downloadable manuals & CAD drawings
- Manufacturer's suggested retail price list
- Product training schedule & locations
- Advertising & trade show schedules
- Press releases & FAQs

www.idec.com/safety

Intrinsically Safe Explosion-Proof: EB3C Relay Barriers

EB3C Key features include:

Explosion Protection

Relay Barrier:	[Exia] II C
----------------	-------------

- IEC60079 compliant
- Dry-contact switches with 0.5Ω maximum contact resistance can be connected to the EB3C.
- 8- and 16-circuit types are available in common wiring types, ideal for connection to PLCs.
- Universal AC power voltage (100 to 240V AC)
- No grounding required.
- IDEC's original spring-up terminals minimizes wiring time.
- Installation: 35-mm-wide DIN rail mounting or direct panel mounting
- Global usage
USA: FM
Canada: CSA
Europe: CE marking, ATEX



Illuminated Pushbutton/Selector Switches

Illuminated pushbutton/selector switches can be used with the combination of EB3C.



Dry Contact Switches

Dry-contact switches with 0.5Ω maximum contact resistance can be connected to the EB3C.

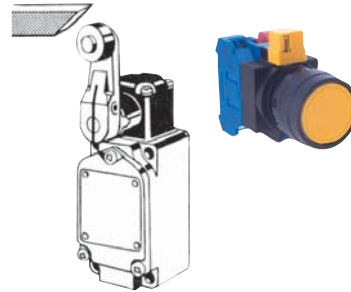

Common Wiring for PLC Inputs

8- and 16-circuit types are available in common wiring types, ideal for connection to PLCs.

Spring-up Fingersafe Terminals Reduce Wiring Time

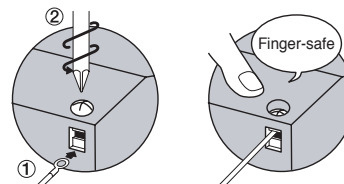

Overview

X Series E-Stops

Door Interlock Switches

Enabling Switches

Barriers

AS-Interface Safety at Work

Specifications

Explosion-Protection and Electrical Specifications

Explosion Protection		Intrinsic safety type (IEC compliant) [Exia] II C		
Degree of Protection		IP20 (IEC60529)		
Installation Location	Relay Barrier	Safe indoor place (non-hazardous area)		
	Switch	For zone 0, 1, 2 hazardous areas		
Non-intrinsically Safe Circuit Maximum Voltage (Um)		250V AC 50/60Hz, 250V DC		
Intrinsically Safe Circuits	Wiring Method	1-channel Separate Wiring	16-channel Common Wiring	
	Rated Operating Voltage	12V DC ±10%		
	Rated Operating Current	10 mA DC ±20%		
	Maximum Output Voltage (Uo)	13.2V DC		
	Maximum Output Current (Io)	14.2 mA	227.2 mA	
	Maximum Output Power (Po)	46.9 mW	750 mW	
	Maximum External Inductance (Lo)*	175 (125) mH	0.68 (0.68) mH	
	Maximum External Capacitance (Co)*	900 (740) nF		
	Allowable Wiring Resistance (Rw)	300Ω	600/(n+1)Ω (n = number of common channels)	
	Maximum Channels per Common Line	—	16	
Non-intrinsically Safe Circuits	Relay Output	Contact Configuration	1NO	
		Rated Insulation Voltage (Ui)	250V AC, 125V DC	
		Thermal Current (Ith)	3A (common terminal: 8A)	
		Contact Allowable Power	Resistive Load	AC: 750 VA, DC: 72W
			Inductive Load	AC: 750 VA (cos φ = 0.3 to 0.4) DC: 48W (L/R = 7 ms)
		Rated Load	Resistive Load	250V AC 3A, 24V DC 3A
			Inductive Load	250V AC 3A (cos φ = 0.3 to 0.4) 24V DC 2A (L/R = 7 ms)
		Minimum Applicable Load	0.1V DC, 0.1 mA (reference value)	
		Contact Resistance	50 mΩ	
		ON Time	12 ms maximum (rated voltage)	
	OFF Time	10 ms maximum (rated voltage)		
	Mechanical Life	20,000,000 operations minimum (at 18,000 operations/hour, without load)		
		Electrical Life		100,000 operations minimum (at 1,800 operations/hour, rated load)
	Short-circuit Protection	None		
	Transistor Output	Rated Voltage	24V DC	
		Maximum Voltage	30V DC	
		Maximum Current	100 mA (connector type: 15 mA)	
		Leakage Current	0.1 mA maximum	
		Voltage Drop	1V maximum	
		Clamping Voltage	33V (1W)	
Inrush Current		0.5A maximum (1 sec)		
ON Time		0.1 ms maximum (resistive load)		
OFF Time		0.4 ms (typical) (resistive load)		
Short-circuit Protection		None		

General Specifications

	AC	DC
Rated Voltage	100 to 240V AC	24V DC
Allowable Voltage Range	85 to 264V AC	21.6 to 26.4V DC
Rated Frequency	50/60 Hz (allowable range: 47 to 63 Hz)	—
Inrush Current	10A (100V AC) 20A (200V AC)	10A
Dielectric Strength (1 minute, 1 mA)	Between intrinsically safe circuit and non-intrinsically safe circuit: 1500V AC	
	Between AC power and output terminal: 1500V AC	
	Between DC power and transistor output terminal: 1000V AC	
Operating Temperature	-20 to +60°C (no freezing)	
Storage Temperature	-20 to +60°C (no freezing)	
Operating Humidity	45 to 85% RH (no condensation)	
Atmosphere	800 to 1100 hPa	
Pollution Degree	2 (IEC60664)	
Insulation Resistance	10 MΩ minimum (500V DC megger, between the same poles as the dielectric strength)	
Vibration Resistance	Damage Limits	Panel mounting: 10 to 55 Hz, amplitude 0.75 mm DIN rail mounting: 10 to 55 Hz, amplitude 0.35 mm
	Operation Extremes (relay output only)	Panel mounting: 10 to 55 Hz, amplitude 0.5 mm DIN rail mounting: 10 to 55 Hz, amplitude 0.35 mm
Shock Resistance	Damage Limits	Panel mounting: 500 m/s ² (3 times each on X, Y, Z) DIN rail mounting: 300 m/s ² (3 times each on X, Y, Z)
		Terminal Style
Mounting	35-mm-wide DIN rail or panel mounting (M4 screw)	
Power Consumption (approx.)	9.6 VA (EB3C-R10A at 200V AC) 4.8 W (EB3C-R16CD at 24V DC)	
Weight (approx.)	0.39 kg (EB3C-R16CD)	

Certification Number

Certification Organization	Explosion Protection	Certification Number
FM	Class I, II, III Div. 1 Group A, B, C, D, E, F, G	3015417 (terminal type)
	Class I, Zone 0 AEx [ia] IIC	
CSA	Class I Div. 1 Group A, B, C, D	166730
NEMKO	[EExia] II C	Nemko 02ATEX279
TIIS Japan	Relay barrier: [Exia] II C	C15753
Class NK	Exia II C	02T606



Class NK is Korean Shipping agency approval.



Values in () are those approved by TIIS (Technology Institution of Industrial Safety, Japan).

Part Numbers

Relay Barriers

Power Voltage	Number of Channels	Connection to Non-intrinsically Safe Circuit	Input Wiring Method	Output	Part Number	
100 to 240V AC	1	Screw Terminal	Separate/Common Wiring Compatible	Relay	EB3C-R01A	
	2				EB3C-R02A	
	3				EB3C-R03A	
	5				EB3C-R05A	
	6				EB3C-R06A	
	8				EB3C-R08A	
	10		EB3C-R10A			
	8		Common Wiring Only	EB3C-R08CA		
	6		Separate/Common Wiring Compatible	EB3C-T06A		
	8			EB3C-T08A		
	10			EB3C-T10A		
	24V DC		8	Screw Terminal	Common Wiring Only	Transistor (Sink)
8		Common Wiring Only	Relay		EB3C-R08CD	
10		Separate/Common Wiring Compatible			EB3C-R10D	
16		Common Wiring Only			EB3C-R16CD	
10		Separate/Common Wiring Compatible	Transistor (Sink/Source)		EB3C-T10D	
8		Common Wiring Only	Transistor		Sink	EB3C-T08CKD
16					Source	EB3C-T16CKD
8			Source		EB3C-T08CSD	
16			Source		EB3C-T16CSD	

Accessories

Item	Part Number	Description
DIN Rail	BAA1000	Aluminum (1m long, 7.5mm high)
	BNDN1000	Aluminum (1m long, 10.5mm high)
Mounting Clip	BNL5	

All dimensions in mm.

Circuit Diagrams

Internal Circuit Block Diagrams
AC Power, Relay Output Type

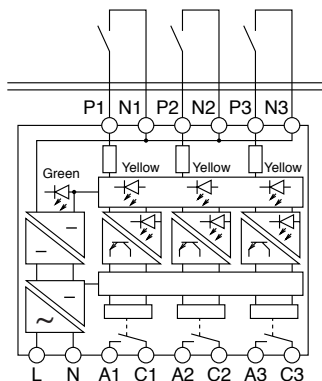

DC Power, Transistor Output Type

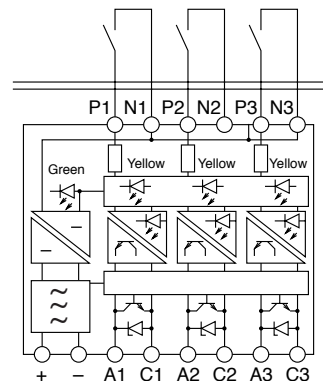

Connector Wiring, Sink Output Type

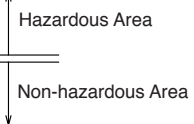
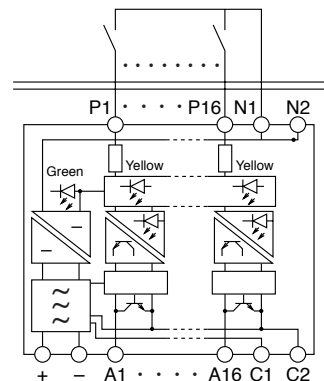

Wiring Examples

External Wiring Examples

Transistor Sink Output Type (Ex.: EB3C-T08CKD)

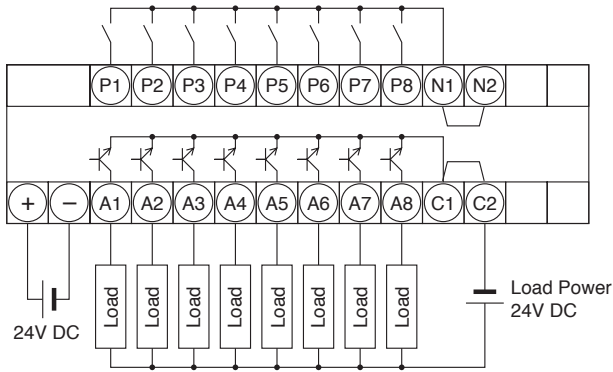

Transistor Source Output Type (Ex.: EB3C-T08CSD)

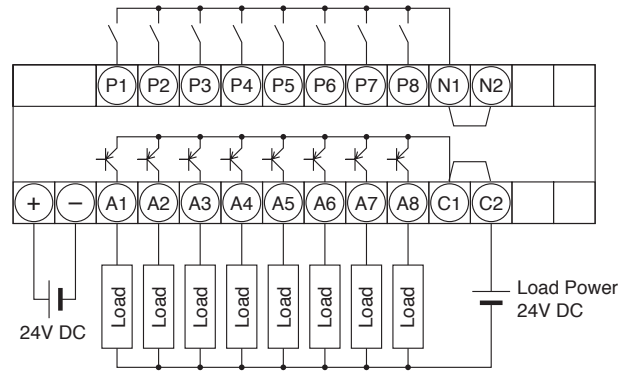

Relay Output Type (Ex.: EB3C-R06A)

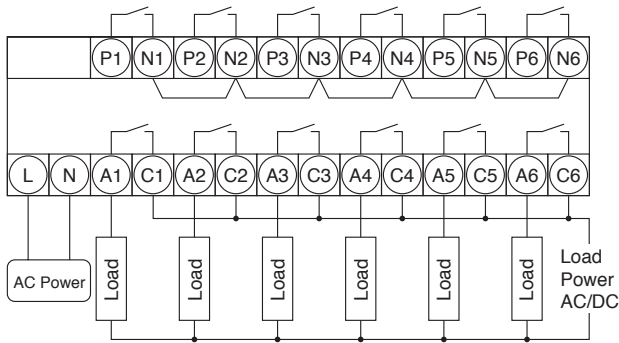

Transistor Output Type (Ex.: EB3C-T06A)

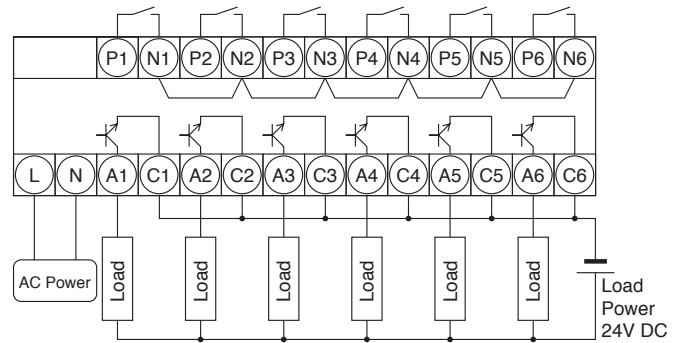

Dimensions (mm)

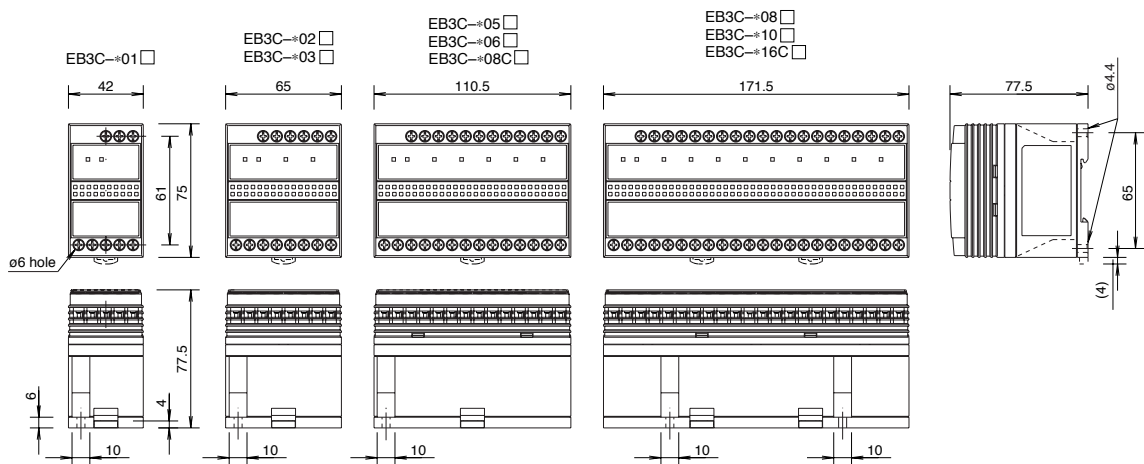

Mounting Hole Layout (Screw Mounting)

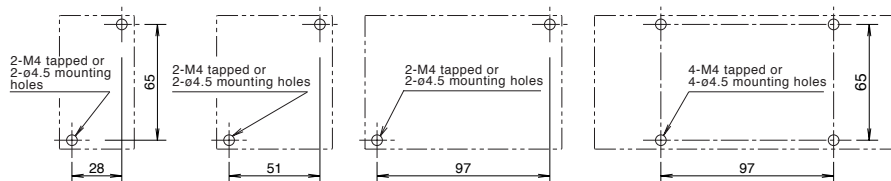

Overview

X Series E-Stops

Door Interlock Switches

Enabling Switches

Barriers

AS-Interface Safety at Work