

M-Max Series



40.1 M-Max Series Adjustable Frequency AC Drive

Product Description	2
Features	2
Catalog Number Selection	3
Product Selection	3
Accessories	4
Technical Data and Specifications	5
Standards	7
Dimensions	7

Note: Supplement to Publication No. CA08102001E—Tab 40.

M-Max Series Drives for Machinery Applications



Contents

Description	Page
Catalog Number Selection	3
Product Selection	3
Accessories	4
Technical Data and Specifications	5
Standards	7
Dimensions	7

Product Description

Eaton's M-Max™ Series sensorless vector adjustable frequency AC drives are the next generation of drives specifically engineered for today's machinery applications. These micro-processor-based drives have standard features that can be programmed to tailor the drive's performance to suit a wide variety of application requirements. The M-Max product line uses a 32-bit microprocessor and insulated gate bipolar transistors (IGBTs) that provide quiet motor operation, high motor efficiency and smooth low-speed performance. The size and simplicity of the M-Max make it ideal for hassle-free installation. Models rated at 480 volts, three-phase, 50/60 Hz are available in sizes ranging from 1/2 to 10 hp. Models rated at 240 volts, single- or three-phase, 50/60 Hz are available in sizes ranging from 1/4 to 3 hp. Models rated at 115 volts, single-phase, 50/60 Hz are available in the 1/4 to 1-1/2 hp size range.

The standard drive includes a digital display, and operating and programming keys on a visually appealing, efficient application programming interface. The display provides drive monitoring, as well as adjustment and diagnostic information. The keys are used for digital adjustment and programming of the drive, as well as for operator control. Separate terminal blocks for control and power wiring are provided for customer connections.

Features of Eaton's M-Max Drive

- Ease of use—plug-and-play, startup wizard, diagnostic capabilities
- Compact, space-saving design
- Rugged and reliable—thoroughly tested with a number of built-in protections
- DIN rail and screw mountable
- Side-by-side installation
- Parameter upload and download without the need for a main power supply
- Integrated EMC filters make the unit suitable for commercial and industrial networks
- Available in the enclosure Class IP20 as standard, options for IP21 and NEMA® 1
- Conformal-coated boards as standard
- Brake chopper as standard in three-phase, 480V, 2 hp and higher
- Temperature-controlled fan
- RS-485/Modbus® as standard
- PI controller as standard
- Several fieldbus options
- RoHS compliant

Catalog Number Selection

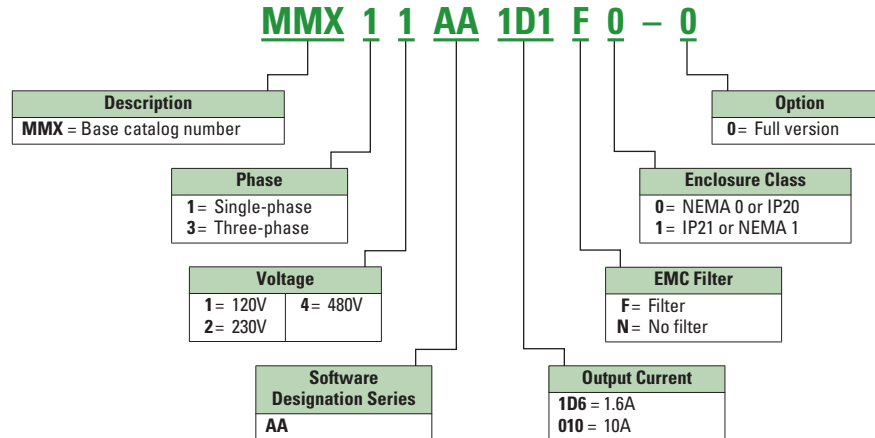

Product Selection

M-Max



M-Max Basic Controller

hp ^①	Volts ^②	100% Continuous Current I _N (A)	Nominal Input Current (A)	Frame Size	Catalog Number	Price U.S. \$ ^{③④}
1/4	100–120V single-phase in 230V three-phase out	1.7	9.2	FS2	MMX11AA1D7N0-0 ^④	235.00
1/2		2.4	11.6	FS2	MMX11AA2D4N0-0 ^④	290.00
3/4		2.8	12.4	FS2	MMX11AA2D8N0-0 ^④	307.00
1		3.7	15	FS2	MMX11AA3D7N0-0 ^④	355.00
1-1/2		4.8	16.5	FS3	MMX11AA4D8N0-0 ^④	450.00
1/4	200–240V single-phase in 230V three-phase out	1.7	4.2	FS1	MMX12AA1D7F0-0	250.00
1/2		2.4	5.7	FS1	MMX12AA2D4F0-0	352.00
3/4		2.8	6.6	FS1	MMX12AA2D8F0-0	370.00
1		3.7	8.3	FS1	MMX12AA3D7F0-0	406.00
1-1/2		4.8	11.2	FS2	MMX12AA4D8F0-0	412.00
2		7	14.1	FS2	MMX12AA7D0F0-0	532.00
3		9.6	15.8	FS3	MMX12AA9D6F0-0	622.00
1/4	200–240V three-phase in 230V three-phase out	1.7	2.7	FS1	MMX32AA1D7N0-0 ^④	261.00
1/2		2.4	3.5	FS1	MMX32AA2D4N0-0 ^④	345.00
3/4		2.8	3.8	FS1	MMX32AA2D8N0-0 ^④	360.00
1		3.7	4.3	FS1	MMX32AA3D7N0-0 ^④	458.00
1-1/2		4.8	6.8	FS2	MMX32AA4D8N0-0 ^④	478.00
2		7	8.4	FS2	MMX32AA7D0N0-0 ^④	547.00
3		11	13.4	FS3	MMX32AA011N0-0 ^④	605.00
1/2	380–480V three-phase in 460V three-phase out	1.3	2.2	FS1	MMX34AA1D3F0-0	429.00
3/4		1.9	2.8	FS1	MMX34AA1D9F0-0	437.00
1		2.4	3.2	FS1	MMX34AA2D4F0-0	442.00
1-1/2		3.3	4	FS1	MMX34AA3D3F0-0	475.00
2		4.3	5.6	FS2	MMX34AA4D3F0-0	572.00
3		5.6	7.3	FS2	MMX34AA5D6F0-0	727.00
4		7.6	9.6	FS3	MMX34AA7D6F0-0	791.00
5		9	11.5	FS3	MMX34AA9D0F0-0	855.00
7-1/2		12	14.9	FS3	MMX34AA012F0-0	1,297.00
10		14	18.7	FS3	MMX34AA014F0-0	1,632.00

Notes

- ① Horsepower ratings are based on the use of a 240V or 480V NEMA B, four- or six-pole squirrel cage induction motor and are for reference only. Units are to be selected such that the motor current is less than or equal to the MMX rated continuous output current.
- ② For 208V, 380V or 415V applications, select the unit such that the motor current is less than or equal to the MMX rated continuous output current.
- ③ There is a discount to this published list price for units without filters:
for FS1, subtract \$25; for FS2, subtract \$33; for FS3, subtract \$45. This does not apply to MMX11... catalog numbers.
- ④ For MMX11... and MMX32..., there are no options for units with filters.
- ⑤ Discount Symbol: **SS-1**.

40.1

Adjustable Frequency Drives

M-Max Series Adjustable Frequency AC Drive

Accessories

MMX-COM-PC

M-Max Module



Description	Catalog Number	Price U.S. \$ ^①
Module is plugged onto the front of the drive to provide: upload/download of all parameters, direct link to a PC via USB interface for parameter assignment via MaxConnect software, and copying of parameters for a series of devices or when exchanging devices. No PC required	MMX-COM-PC	158.00

Note

^① Discount Symbol: **SS-1**.

Technical Data and Specifications

Ratings

M-Max Basic Controller IP20 Standard Ratings

Description	Specification
Standards	
Product	Complies with EN61800-3 (2004)
Safety	61800-5-1, EN60204-1, CE, UL®, cUL®, IEC (see unit nameplate for more detailed approvals)
EMC (at default settings)	EMC level H: with an internal RFI filter option
Protections	
Overcurrent Protection	Trip limit $4.0 \times I_H$ instantaneously
Overvoltage Protection	115/230V series: 437 Vdc; 400V series: 874 Vdc trip level
Undervoltage Protection	115/230V series: 183 Vdc; 400V series: 333 Vdc trip level
Ground Fault Protection	Ground fault is tested before every start. In case of ground fault in motor or motor cable, only the frequency converter is protected
Overtemperature Protection	Yes
Motor Overload Protection	Yes
Motor Stall Protection	Yes
Motor Underload Protection	Yes

Programmable Parameters

- Programmable start/stop and reverse signal logic (sinking or sourcing)
- Reference scaling
- Programmable start and stop functions
- DC-brake at start and stop
- Programmable V/Hz curve
- Adjustable switching frequency
- Autorestart function after fault
- Protections and supervisions (all fully programmable; off, warning, fault)
- Current signal input fault
- External fault
- Fieldbus communication
- Eight preset speeds
- Analog input range selection, signal scaling and filtering
- PI controller

Specifications

M-Max Series Drives

Description	Specification
Input Ratings	
Input Voltage (V_{in})	+10% / -15%
Input Frequency (f_{in})	50/60 Hz (variation up to 45 to 66 Hz)
Connection to Power	Once per minute or less (typical operation)
Output Ratings	
Output Voltage	0 to V_{in} ①
Continuous Output Current	Continuous rated current I_N at ambient temperature max. 122°F (50°C), overload $1.5 \times I_N$ max. 1 min/10 min
Output Frequency	0 to 320 Hz
Frequency Resolution	0.01 Hz
Initial Output Current (I_H)	Current $2 \times I_N$ for 2 seconds in every 20-second period Torque depends on motor
Control Characteristics	
Control Method	Frequency control (V/Hz) open loop or sensorless vector control
Switching Frequency	1.5 to 16 kHz; default 6 kHz
Frequency Reference	Analog input: resolution 0.1% (10-bit), accuracy $\pm 1\%$ V/Hz Panel reference: resolution 0.01 Hz
Field Weakening Point	30 to 320 Hz
Acceleration Time	0 to 3000 sec
Deceleration Time	0 to 3000 sec
Braking Torque	DC brake: $30\% \times T_n$ (without brake option)
Ambient Conditions	
Ambient Operating Temperature	14°F (-10°C), no frost to 122°F (+50°C): rated loadability I_N
Storage Temperature	-40°F (-40°C) to 158°F (70°C)
Relative Humidity	0 to 95% RH, noncondensing, non-corrosive, no dripping water
Air Quality	Chemical vapors: IEC 721-3-3, unit in operation, Class 3C2 Mechanical particles: IEC 721-3-3, unit in operation, Class 3S2
Altitude	100% load capacity (no derating) up to 3280 ft (1000m); 1% derating for each 328 ft (100m) above 3280 ft (1000m); max. 6560 ft (2000m)
Vibration	EN 60068-2-6; 3 to 150 Hz, displacement amplitude 1 mm (peak) at 3 to 15.8 Hz, max. acceleration amplitude 1G at 15.8 to 150 Hz
Shock	EN 50178, IEC 68-2-27 UPS Drop test (for applicable UPS weights); storage and shipping: max. 15G, 11 ms (in package)
Enclosure Class	IP20

Note

① Exception: 115V in, 230V out.

40.1

Adjustable Frequency Drives

M-Max Series Adjustable Frequency AC Drive

M-Max I/O Interface

Terminal	Signal	Factory Preset	Description
1	+10V	—	Ref. output voltage Maximum load 10 mA
2	AI1	Freq. reference ^{P)}	0–+10 V Ri = 200k ohms (min.)
3	GND	—	I/O signal ground
6	24V	—	24V output for DIs ±20%, max. load 50 mA
7	GND	—	I/O signal ground
8	DI1	Start forward ^{P)}	0–+30 V Ri = 12k ohms min.
9	DI2	Start reverse ^{P)}	—
10	DI3	Preset speed ^{P)}	—
A	A	RS-485 signal A	FB communication
B	B	RS-485 signal B	FB communication
4	AI2	PI actual value ^{P)}	0[4]–20 mA, Ri = 200k ohms
5	GND	—	I/O signal ground
13	GND	—	I/O signal ground
14	DI4	Preset speed B1 ^{P)}	0–+30 V Ri = 12k ohms min.
15	DI5	Fault reset ^{P)}	0–+30 V Ri = 12k ohms min.
16	DI6	Disable PI contr. ^{P)}	0–+30 V Ri = 12k ohms min.
18	AO	Output frequency ^{P)}	0[4]–20 mA, RL = 500k ohms
20	DO	Digital signal out	Active = READY ^{P)} Open collector, max. load 48V/50 mA
22	R011	Relay out 1	Active = RUN ^{P)} Max. switching load: 250 Vac/2A or 250 Vdc/0.4A
23	R012		
24	R021	Relay out 2	Active = FAULT ^{P)} Max. switching load: 250 Vac/2A or 250 Vdc/0.4A
25	R022		
26	R023		

Note

P) Parameter-selectable function.

40

Standards

I/O Specifications

- Digital inputs DI1 ... DI6 are freely programmable. The user can assign a single input to many functions
- Digital, relay and analog outputs are freely programmable

Includes:

- Six digital inputs
- Two analog inputs
 - 4–20 mA
 - 0–10V
- One analog output
- One digital output
- Two relay outputs
- RS-485 interface

Reliability

- Pretested components: standard
- Computerized testing: standard
- Final test with full load: standard
- Conformal-coated boards
- 50°C rated
- 150% for 1 minute
- Eaton Electrical Services & Systems: national network of AF drive specialists

Dimensions

Approximate dimensions in inches (mm)

M-Max Series Drives

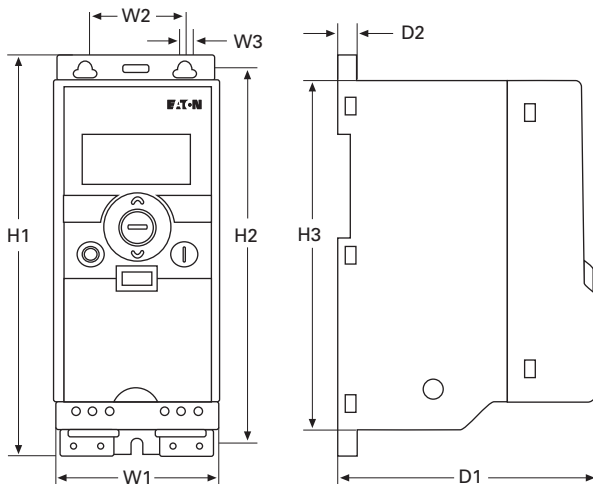

Frame Type	H1	H2	H3	W1	W2	W3	D1	D2	Weight Lbs (kg)
FS1	6.16 (156.5)	5.79 (147.0)	5.40 (137.3)	2.58 (65.5)	1.49 (37.8)	0.17 (4.5)	4.02 (102.0)	0.27 (7.0)	1.213 (0.550)
FS2	7.68 (195.0)	7.20 (183.0)	6.69 (170.0)	3.54 (90.0)	2.46 (62.5)	0.22 (5.5)	4.13 (105.0)	0.27 (7.0)	1.543 (0.699)
FS3	10.33 (262.5)	9.93 (252.3)	9.50 (241.3)	3.94 (100.0)	2.95 (75.0)	0.22 (5.5)	4.41 (112.0)	0.27 (7.0)	2.183 (0.990)

Eaton's electrical business is a global leader in power distribution, power quality, control, and industrial automation products and services. Eaton's global electrical product lines, including Cutler-Hammer®, Moeller®, Powerware®, Holec®, MEM®, Santak®, and MGE Office Protection Systems™, provide customer-driven PowerChain Management® solutions to serve the power system needs of the data center, industrial, institutional, government, utility, commercial, residential, and OEM markets worldwide.

PowerChain Management solutions help enterprises achieve sustainable and competitive advantages through proactive management of the power system as a strategic, integrated asset throughout its life cycle. With Eaton's distribution, control, and power quality equipment; full-scale engineering services; and information management systems, the power system is positioned to deliver powerful results: greater reliability, operating cost efficiencies, effective use of capital, enhanced safety, and risk mitigation.

Eaton Corporation
Electrical Sector
1111 Superior Ave.
Cleveland, OH 44114
United States
877-ETN-CARE (877-386-2273)
Eaton.com

© 2009 Eaton Corporation
All Rights Reserved
Printed in USA
Publication No. CA04020001E / Z8934
July 2009



PowerChain Management is a registered trademark of Eaton Corporation.

All other trademarks are property of their respective owners.